

# Operation and Maintenance guide

# 'Waterway SkyJet'

For Installation and Service Engineers



## Important!

**This installation of this product is to be carried out by Competent Engineers.**

**READ THIS BOOKLET before installation of this product.**

**Retain this booklet as it contains important information for the safe and proper use of this product.**

All electrical wiring must comply with all National and Local Electrical Codes.

This product complies with the European Directive on Low Voltage Safety, and contains components designed to promote compliance with the European EMC Directive.

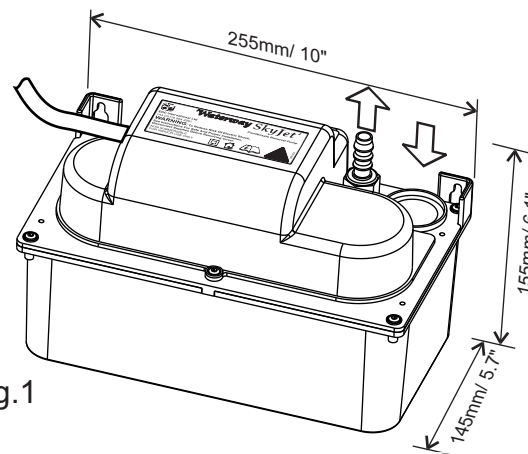

fig.1

## Description of Operation

The Waterway Skyjet is an Automatic Condensate Removal Pump for use with Air Conditioning and Refrigeration Equipment. It can also pump away the hot water away from humidifiers used with these air conditioners (see note 1.).

### Specification

	Model	Power Supply:	Tubing Size	Cable Length
Euro:	SKJ.0075.1	230V 50/60Hz 50W	6.0mm/ 1/4" ID	1.5M/ 4ft 10" - 0.75mm <sup>2</sup>
US:	SKJ.0075.2	208-240V 50/60Hz 50W	10mm/ 3/8" ID	1.83M/ 6ft - 18AWG
US:	SKJ.0075.3	110-120V 50/60Hz 50W	10mm/ 3/8" ID	1.83M/ 6ft - 18 AWG

Relay: 6A 250V, Class II Isolation.  
Break on Alarm.

Protection: IP20

Operating Temperature: Air 50°C / 122°F  
Water 25°C / 77°F  
(for intermittent use with hot water see note 1)

Pumping Capacity: See Graph  
Discharge Head: 50 metres/164ft max, see fig.2.  
(10metres/ 33ft for Humidifier Dump water see note 1.)

Max Tube Length: 100 metres/ 328ft

Max Tank Capacity: 2.0 Litres.

Thermal Protection: Auto-reset at 85°C 122°F.

fig.2 Capacity Chart

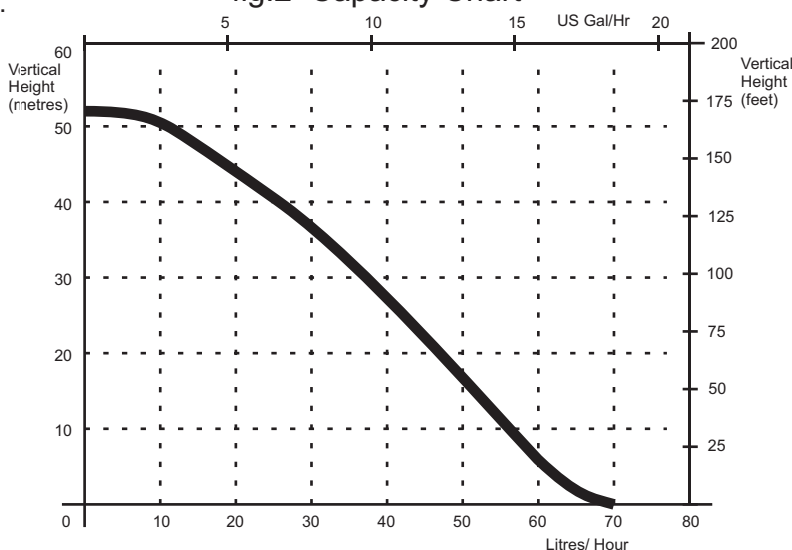

## Tubing Requirements.

PVC Reinforced Braided Hose is typically suitable for water temperature up to 65°C Max. When using with Humidifier Dump water, select a tube suitable for high temperature water -refer to suppliers data for suitability.

Un-reinforced PVC tubing - refer to suppliers data for suitability.

Note 1 : The Sky Jet has been designed to pump hot water back flush from electrode-boiler humidifiers. Maximum discharge height is 10 metres with water up to 95 °C from a close-coupled humidifier drain dumping up to 1.7 litres every 30 minutes (extreme conditions).



**EDC International Ltd**  
Brook House, 14 Station Road,  
Pangbourne, Reading, England  
RG8 7AN  
Tel: +44(0)118 9842991.  
Fax: +44(0)118 9845300  
[www.edcinternational.com](http://www.edcinternational.com)

**EDC International, Inc**  
273, Canal Street, Suite 224, Shelton, CT6485 U.S.A  
Phone:(203)922 1886

**EDC Technologies Asia Pte Ltd**  
21004 Toa Payoh North #06-08, Singapore, 318995  
Phone:+65252 8030 Fax+65 252 3682

## INSTALLATION

### Location

Select a suitable location for the pump near the appliance allowing for periodic maintenance and inspection. Make sure the hose from the condensate tray to the Inlet port of the pump, travels down hill all the way, avoiding long runs. The Collection tank has mounting holes for two # 8 Round Head screws for securing the pump level on an adjacent wall or panel (Use suitable expanding fasteners if fixing to brick, block or plasterboard).

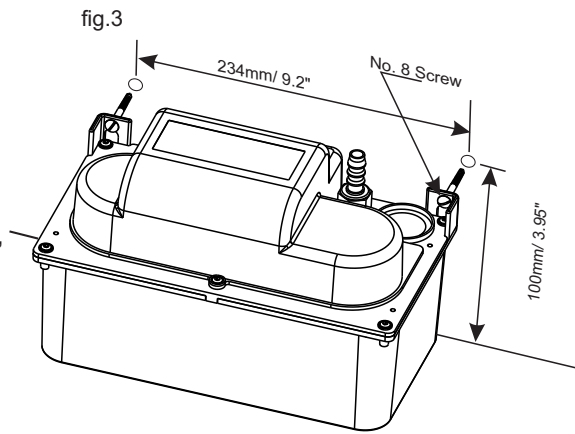

### Piping

Run a suitable drain hose from the condensate collection tray to the Pump Inlet so the end is 2"/ 50mm inside the collection tray (fig.4). Use a flexible hose where permitted to allow periodic inspection and maintenance. Run discharge tubing to a suitable drain where it is unlikely to freeze during operation. The highest point of the run must be less than 150ft/ 50m above the Pump. Take care not to pinch or kink the tubing as this will block the flow.

fig.4 MAX/ MIN HEAD, DRAIN HOSE  
50m/ 164ft max  
(see note 1.)

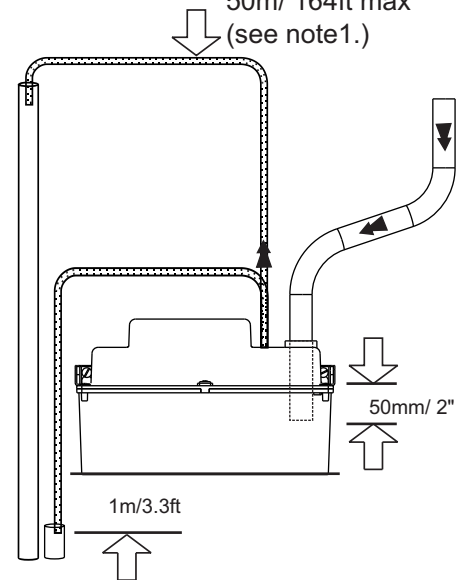

### Wiring

**WARNING! SWITCH OFF ALL SUPPLIES AT THE FUSE BOX BEFORE MAKING CONNECTIONS TO THIS PUMP.**

This pump does not require a ground connection.

The installation must provide a suitable means for electrical disconnection.

Fuse Protection Required Europe 3Amax.

USA. Factory fitted cable is 18 awg. Refer to National and Local Electrical Codes for fusing and disconnection requirements.

Leave enough flexible cable unfixed for servicing.

#### Supply Cable Colour Coding

##### EUROPEAN

BROWN	L	LIVE PHASE
BLUE	N	NEUTRAL

##### USA

BLACK	L1	LIVE PHASE
WHITE	L2	NEUTRAL ( PHASE 2, 220V SYSTEM)

fig.5 WIRING EXAMPLE

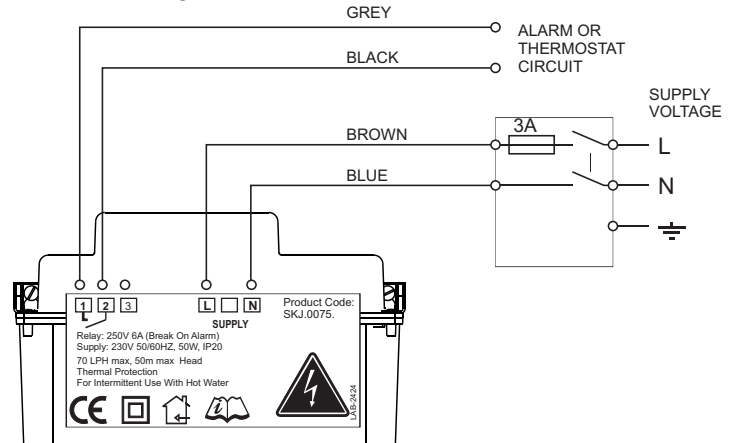

### Alarm Relay

The alarm relay is energised to make continuity during normal operating conditions (break on fault).

It is class II Isolated, suitable for use with low voltage thermostat control systems.

**CAUTION:** DISCONNECT THE POWER SUPPLY BEFORE PERFORMING ANY SERVICING OR MAINTENANCE. ONLY COMPETENT PERSONS SHOULD ATTEMPT TO SERVICE THIS PRODUCT.

fig.6

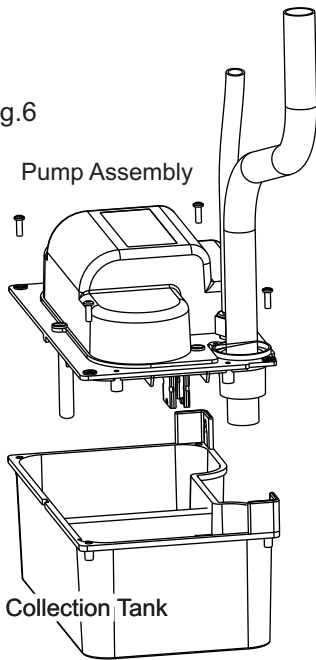

### Inspection and Maintenance

Remove the 4 fixing screws from the corners (fig. 6) to separate the pump assembly collection tank. Lift the Pump assembly up and away from the tank.

Keep Pump Assembly reasonably upright to prevent any water spills from entering the electrics. If necessary support the Pump Assembly to prevent excessive strain on cables and connections.

Inspect the filter and contents of the tank for sediment and debris. If cleaning is required- loosen the wall mounting screws enough to lift the tank away using the slots (fig. 7).

Lift the filter out of the location slot and rinse under a tap with clean water. Clean the inside of the tank with a brush and rinse out with clean water.

On the underside of the Pump Assembly, check for debris between the sensor plates (fig. 8). Clean gently with a soft cloth or Q-tip. Do not scratch sensitive surface.

Inspect the Suction Tube (fig.8) for dirt and blockages and clean if required. Do not use detergents in servicing this product.

Re-position the filter making sure it is positioned fully on the base of the collection tank (fig.9).

Assemble the main pump assembly into the collection tank making sure no dirt is picked up in the process. Secure the main pump assembly to the tank with the 4 screws.

Inspect the discharge tube for blockages and kinks.

Locate and re-secure to the wall using the mounting screws.

All mounting and fixing screws should be in place to assure safe and proper operation.

### Evaporator / Coil Cleaning.

When using evaporator cleaning agents, drain discharged liquid into a separate container and flush with clean water. Do not allow cleaning agents and dirt to drain into Pump.

fig.7 key hole slot for wall mounting

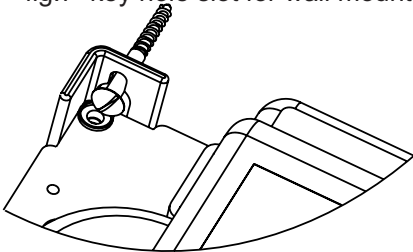
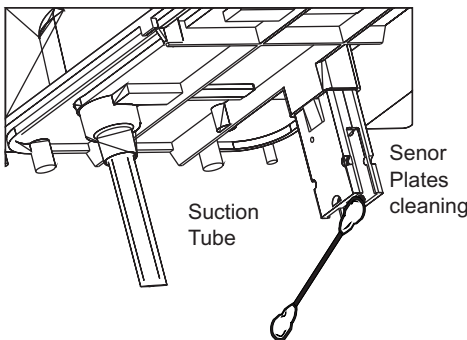

fig.8 underside of pump



### Testing

On new installations, flush installation debris through condensate system into a bucket, before connecting the pump.

To test the operation of the pump the tank will need filling with 1.5L / 3 US Pints of clean water. If possible fill via the condensate collection tray to check also the water drain route. If not possible, remove the drain hose from the inlet and carefully fill using a funnel to prevent spillage.

The pump should begin to pump until all, but approximately 1.5cm / 5/8" of water is left remaining.

fig.9

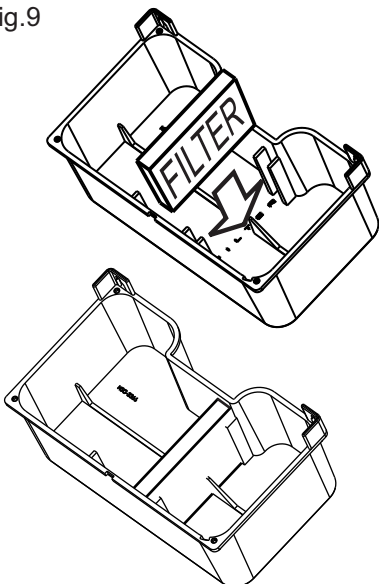

### Filtering

The filter fitted is to prevent large debris such as fibers, scale and slime from blocking the pump mechanism and tubes. The filter is removable and washable. It extends the life of the pump and should be carefully fitted.

On sealed and filtered air flow systems in clean environments, where clean condensate is produced, the filter may be removed providing the system is flushed through first. If in doubt keep the filter fitted.

## Troubleshooting

Pump Not Operating or operating intermittently:

- Check Supply Fuse.
- Check the filter (see inspection and maintenance).
- Check Discharge tube for blockages.
- Check Tube connections are secure and water tight.
- See Note 2

Water Overflowing or Leaking:

- Check the pump is secure and level.
- Check Discharge tube for blockages.
- Check Tube connections are secure and water tight.
- Check Supply Fuse.
- Check the filter (see inspection and maintenance).

Note 2. The pump motor is protected by an automatic self re-setting thermal overload. This will cause the pump to stop if the discharge tube is blocked or debris built up on the sensor plates causing the pump to pump air. Shut Off power for 30 minutes to allow to cool. Perform full service routine and test. If problems still occur, Replace complete Pump.

## Auxiliary Parts

- Replacement Filter Sponge
- 6mm/ 1/4" Hose Connector for 6mm/ 1/4" Discharge Tubing
- Hose Connector for 10mm/ 3/8" Discharge Tubing

## Warranty

*This product is guaranteed for two years to be free from manufacturing defects or faulty materials. If it should fail for either of these reasons within two years from the date of manufacture it will be replaced or repaired free of charge, at the option of EDC International Limited.*

*EDC International Limited can accept no liability whatsoever for any loss or damage arising from the use of this product, however caused. Before using this product the user should satisfy himself that the product is suitable for use in the intended application, and for the manner in which it is intended that it be used. Note that the warranty on this product is void if it has been blocked by dirt or if any part has been mechanically damaged. This product is subject to continuous development and improvement and EDC International Limited reserves the right to alter the specifications or design without prior notice.*

## NOTES:

---

---

---

---

---

---

Leave this Manual with the  
Installation or Owner

*Installed By:*

*On Date:*